



carmanah®

MODEL

M502



Solar-Powered LED Marine Lanterns

Carmanah's Model M502 solar marine lantern offers excellent value and extremely reliable operation for up to five years. With a virtually indestructible design, the Model M502 solar marine lantern is completely waterproof, vibration proof, and vandal resistant. As the next generation in Carmanah's popular, successful 500 series solar lanterns, the Model M502 includes all the features of its Model M501 predecessor, but is also completely programmable.

LIGHT OUTPUT AND OPERATION

Visibility ^{1,2}	1 NM (1.8 km)
Peak intensity (360° average, green LEDs)	~1.2 Candela
Ambient storage temperature	-40 to 176 °F (-40 to 80 °C)
Ambient operating temperature	-22 to 122 °F (-30 to 50 °C)
Autonomy (flashing) at full charge	300 hours
Available LED color	Red, green, blue, amber, or white
Colored lens option	Yes
Flash patterns	7
Programmable (infrared)	Yes

CONSTRUCTION

Light source	High-powered LEDs
Lens material	UV stabilized
Battery (average 5-year life)	Non-replaceable
Energy Management System MICROSOURCE® code suite	Yes
Mounting options	2 Bolt
Weight	2.45 lb (1.1 kg)

PATENTS AND APPROVALS

RoHS compliant	Yes
CE approval	As per EN 60945:1997
IP68 waterproof rating	Yes
Patents	US Patents: 6573659 and 6013985 Other Patents Pending



Marine Clients

- Australian Maritime Systems
- Brazilian Naval Commission
- Canadian Coast Guard
- CETMEF, France
- Indian Port of Kandla, India
- Maritime and Port Authority of Singapore
- NOAA – National Data Buoy Center
- Panama Canal
- Suez Canal, Egypt
- Trinity House Lighthouse Service, UK
- United States Coast Guard
- Vancouver Port Authority

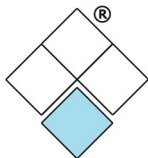

SARTELCO® SISTEMI SRL

Via Torri Bianche, 1
20871 Vimercate (MB)
Tel. +39-039-62905.1 Fax.
+39-039-62905.99
info@sartelco.it
ordini/promozioni@amministratoresartelco.it
www.sartelco.it

Carmanah Technologies Corporation

Building 4-203 Harbour Rd.
Victoria, BC V9A 3S2
Toll Free: +1.877.722.8877
(US & Canada)
Worldwide: +1.250.380.0052
Fax: +1.250.380.0062
Email: info@carmanah.com

we put solar to work™

Side View

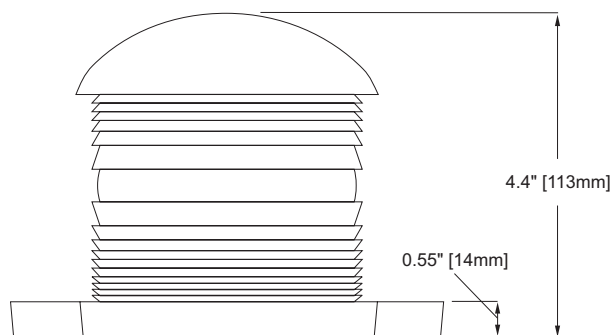

Top View

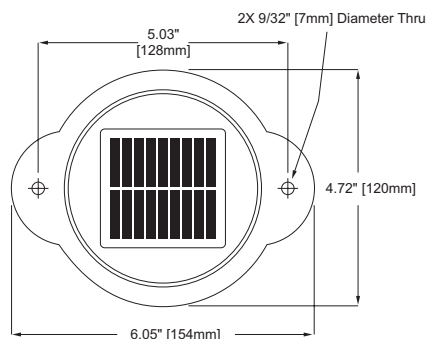

Accessories

Security Bolt



Mounting Plate



Carmanah's Model M502 solar marine lantern is a compact, light-weight, and low maintenance solution for marking small buoys, docks, marinas, aquaculture weirs, and other applications requiring navigation or hazard marking.

The Model M502 is the next generation of the Model M501 solar marine lantern. The Model M502 solar marine lantern features 1 NM (1.8 km) visibility and offers:

- **Maximum capacity with minimal life-cycle cost** – operates up to five years maintenance free³
- **Field-proven durability** – over 250,000 solar installations worldwide
- **IP68 certification** – designed to higher levels of water ingress protection standards
- **Vandal and theft resistant design** – high quality construction and mounting hardware
- **Patented technology** – innovative LED technology and energy management system

The Model M502 is also:

- Manufactured in accordance with ISO 9001:2000 Quality Assurance Standards
- Engineered to meet requirements of the USCG in 33 CFR part 66 for Private Aids to Navigation

¹ Transmissivity of 0.74.

² Actual range is dependant on flash pattern, intensity, and LED color.

³ Dependent on location.

