

F8L10GW LoRaWAN Base Station User Manual	Document Version	Pages
	V3.0.1	
	Model: F8L10GW	Total: 31

F8L10GW LoRaWAN Base Station User Manual

Model	Category
F8L10GW-433	EU433
F8L10GW-470	CN470
F8L10GW-868	EU868
F8L10GW-915	US915



Four-Faith Corporation

Add: 11th Floor, A-06 Area, No.370, Chengyi Street, Jimei,
Xiamen, Fujian, China.

Tel: +86 592-5907276 Fax: +86 592-5912735

Web: en.four-faith.com

Files Revised Record

Date	Version	Remark	Author
2018.07.19	V1.0.0	Initial version	Cheney/Carolin
2018.10.11	V1.0.1	Add 1-3 system block diagram; Modify document format; Document style adjust; Font size adjustment.	Jim Chen
2018.11.06	V2.0.0	Modify “3.3.1 Connection Setting” mode1: wired ethernet connection.	Jim Chen
2019.1.19	V3.0.0	New Version	Jim Chen
2019.1.20	V3.0.1	DC “12~48V” update “9~36V”	Jim Chen

Copyright Notice

All contents in the files are protected by copyright law, and all copyrights are reserved by Xiamen Four-Faith Communication Technology Co., Ltd. Without written permission, all commercial use of the files from Four-Faith are forbidden, such as copy, distribute, reproduce the files, etc., but non-commercial purpose, downloaded or printed by individual (all files shall be not revised, and the copyright and other proprietorship notice shall be reserved) are welcome.

Trademark Notice

Four-Faith、四信、、、 are all registered trademarks of Xiamen Four-Faith Communication Technology Co., Ltd., illegal use of the name of Four-Faith, trademarks and other marks of Four-Faith is forbidden, unless written permission is authorized in advance.



Contents

- Chapter 1 Product Introduction 6
 - 1.1 Overview 6
 - 1.2 Features & Benefits..... 6
 - 1.3 Hardware Block Diagram 7
 - 1.4 Specifications 7
- Chapter 2 Installation 9
 - 2.1 General Packing List 9
 - 2.2 Product Overview 10
 - 2.3 SIM/UIM Card Installation 10
 - 2.4 Wall-mounted Installation 12
 - 2.5 Pole-mounted Installation 13
 - 2.6 Antenna Installation 14
 - 2.7 LED Indicators 14
- Chapter 3 Configuration 15
 - 3.1 Connect with the F8L10GW 15
 - 3.2 Access to configuration pages..... 17
 - 3.3 Web Configuration 18
 - 3.3.1 Setup 18
 - 3.3.1.1 Basic Setup..... 18
 - 3.3.2 Wireless 21
 - 3.3.3 LoRaWAN Application..... 23
 - 3.3.4 Admin..... 24
 - 3.3.4.1 Management 24
 - 3.3.4.2 Factory Defaults 27
 - 3.3.4.3 Firmware Upgrade 27
 - 3.3.4.4 Backup 28
 - 3.3.5 Status..... 29
 - 3.3.5.1 Router..... 29
 - 3.3.5.2 WAN..... 30
 - 3.3.5.3 System Info 31

Chapter 1 Product Introduction

1.1 Overview

F8L10GW is a wireless communication base station based on LoRaWAN protocol. It connects to LoRaWAN terminals of various applications and transmits terminal data to the cloud through 3G/4G or wired Ethernet. Support wireless configuration management and online upgrade, GPS positioning, mains power supply, optional POE power supply, optional DC power supply, etc.

F8L10GW is complied with standard LoRaWAN protocol, it's compatible with LoRaWAN devices and NS. The product has been widely used in M2M industry, smart grid, smart transportation, industrial automation, intelligent buildings, fire control, public security, environmental protection, meteorology, digital medical treatment, telemetry, military, space exploration, agriculture, forestry, water, mining, petrochemical and other fields.

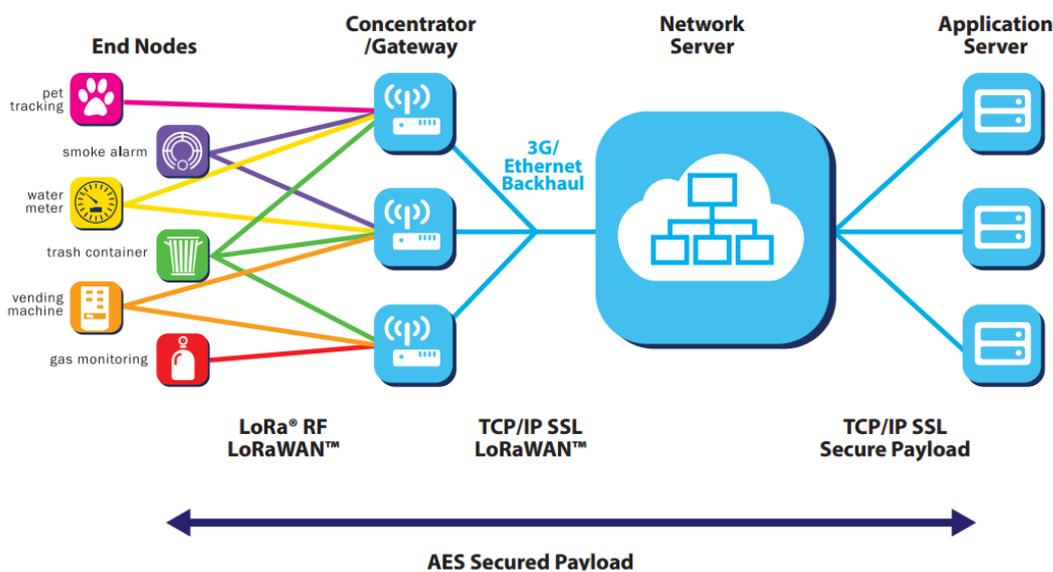

Figure 1-1 Topology Diagram

1.2 Features & Benefits

Industrial-grade Design

- ◆ High performance industrial-grade wireless communication module
- ◆ High performance industrial-grade multi-channel LoRaWAN RF chip
- ◆ Aluminum housing, IP65 metal casting

Stability & Reliability

- ◆ WDT design
- ◆ Complete anti-drop mechanism ensures device always online
- ◆ Ethernet interface with built-in 1.5KV electromagnetic isolation protection
- ◆ SIM/UIM card interface with built-in 15KV ESD protection
- ◆ Built-in reverse phase protection, over voltage protection and lightning protection
- ◆ Antenna lightning protection

1.3 Hardware Block Diagram

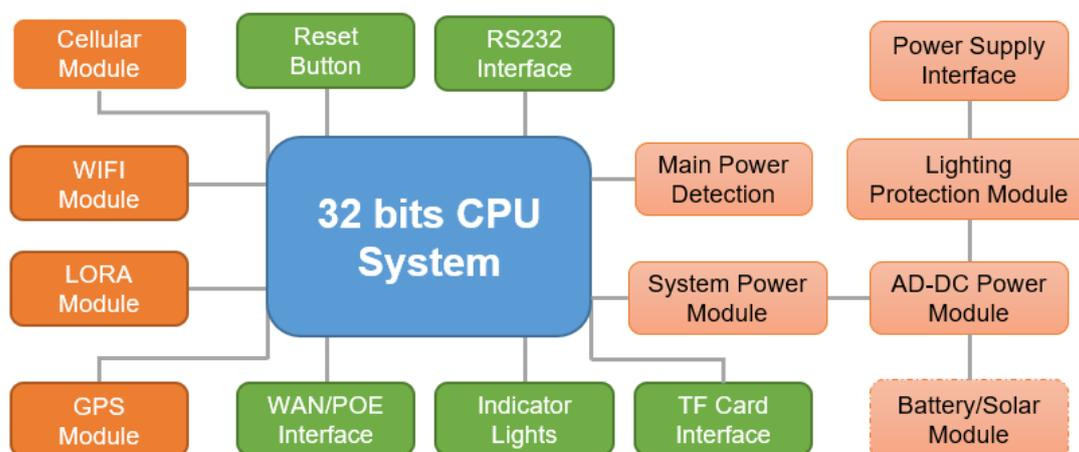

Figure 1-2 Hardware Block Diagram

1.4 Specifications

CHARACTERISTICS	
Network Structure	Simple Star Network Topology and support repeater function
LoRaWAN Protocol	Class A, Class B*, Class C
Band	EU433, CN470-510, CN779-787, EU863-870, US902-928, AU915-928, AS923, KR920-923
Outdoor	6 Km
Out Power	23±2dBm
Sensitivity	-140dbm@LoRa; -70dbm @WIFI
Bandwidth	125kHz \ 250kHz \ 500kHz
Upstream Channel	8
Downstream Channel	1
Communication Rate	ADR
Work Mode	Support receive and send at same frequency or different frequency
Location Service	GPS or Beidou

Server Report Method	3G/4G/Wired Ethernet
Local Storage	32G TF Card
ANTENNA	
LoRa	N-type female antenna, omnidirectional fiberglass antenna, 2dBi
4G Cellular	N-type female antenna, omnidirectional fiberglass antenna, 3dBi
WIFI	N-type female antenna, 2.4G omnidirectional fiberglass antenna, 3dBi
GPS	N-type female antenna, omnidirectional fiberglass antenna, 4dBi
POWER SUPPLY	
Default	Standard AC 220V
Optional-1 (DC)	9~36V
Optional-2 (POE)	10/100 Base-T, IEEE802.3af/IEEE802.3at standard
POWER CONSUMPTION	
Stand By	Average Current ≤ 140mA@12V
Communication	TXD ≤ 550mA@12V RXD ≤ 420mA@12V
PHYSICAL PROPERTIES	
Dimensions	289.4x217.5x115.0 mm (excluding antennas and mountings)
Weight	2700g (excluding antennas, accessories and POE power)
Installation	Wall mount or pole mount (accessories provide)
OTHERS	
Operating Temperature	-40~+85°C (-40~+185°F)
Storage Temperature	-40~+125°C (-40~+257°F)
Relative Humidity	95% (non-condensing)
Certifications	CE & FCC

Chapter 2 Installation

2.1 General Packing List

F8L10GW must be installed correctly and the installation must be conducted by a qualified engineer recognized by Four-Faith.

➤ *Warning:*

1. *Power off before installation*
2. *Don't remove the cover, power interface and antenna interface*

Before you install the F8L10GW, please check the package contents and make sure it completely.

Item		Qty	Remark
F8L10GW		1	
Y-type wrench		1	
4G fiberglass omnidirectional antenna		1	
WIFI fiberglass omnidirectional antenna		1	
GPS fiberglass omnidirectional antenna		1	
LoRa fiberglass omnidirectional antenna		1	
Wall mount	Bracket	1	Select one installation method or select all
	Swelling screw \varnothing 14mm	3	
Pole mount	Fixed Bracket	2	
Power line		1	optional
POE		1	optional
User manual CD		1	optional
QC passed card		1	
Warranty card		1	

Form 2-1 F8L10GW packing list

2.2 Product Overview



- 1 GPS fiberglass omnidirectional antenna interface
- 2 LoRa fiberglass omnidirectional antenna interface
- 3 POE
- 4 4G fiberglass omnidirectional antenna interface
- 5 WIFI fiberglass omnidirectional antenna interface
- 6 AC220

2.3 SIM/UIM Card Installation

1. Unscrew the M6 screw on F8L10GW, and then open it.



2. Put the SIM/UIM card into the card slot.

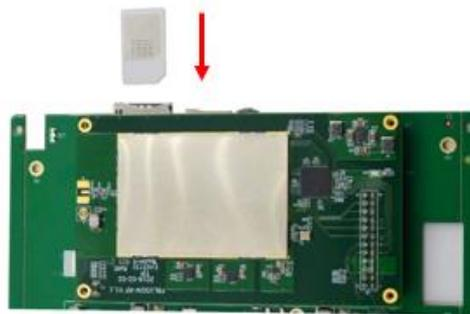

3. If you want to take out the SIM/UIM card, you can push it, and then it will popup automatically.

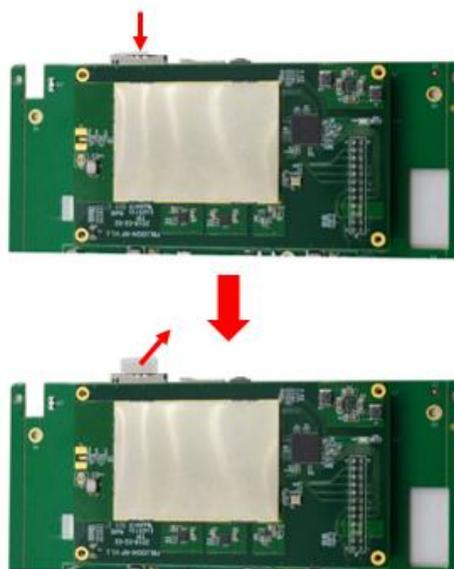

4. Close the shell, and then tighten the M6 screws.

2.4 Wall-mounted Installation

1. Drill 3 holes of $\varnothing 14\text{mm}$ diameter, 60 mm depth according to the position of the bracket.

◆ *Requirement:*

1. *the wall should be flat;*
2. *must be in an open area*
3. *make sure no shield within 5 meters*

2. Fixing the swell screws in the bracket.

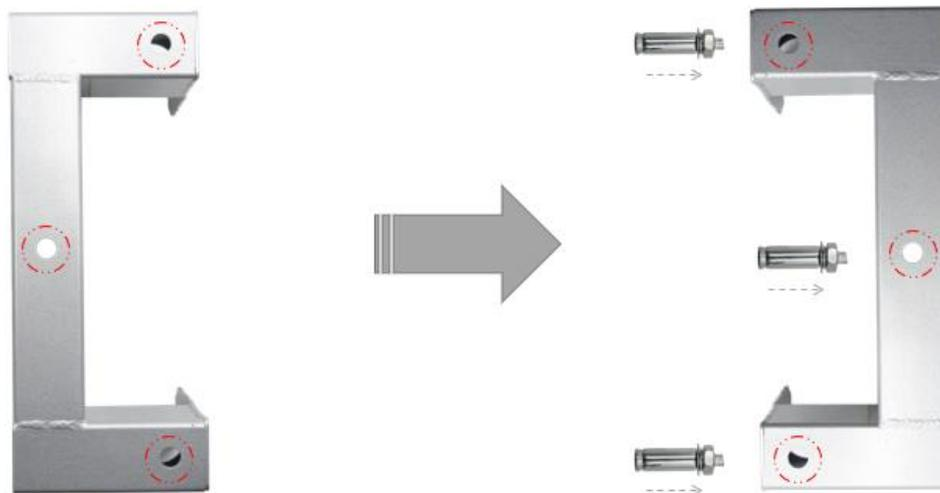

3. Fix the bracket on the wall and tighten the screw.

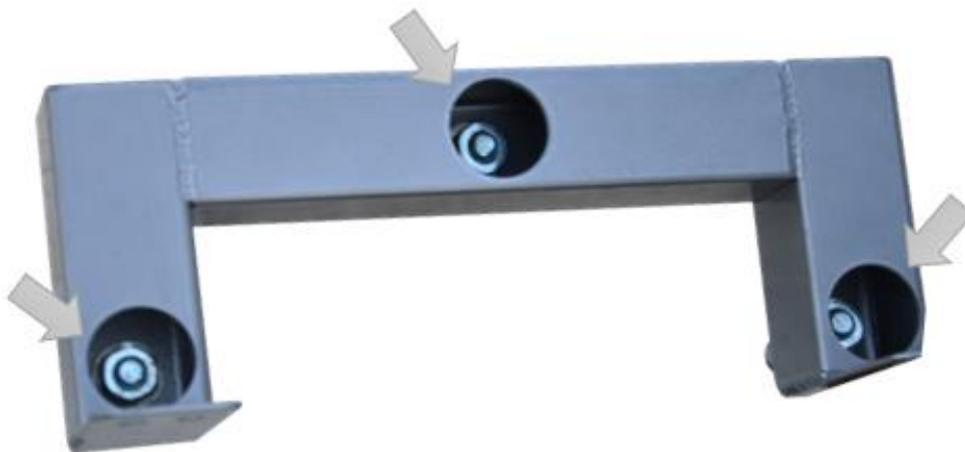

5. Tighten the four screws and fix the base station on the bracket, then install the antenna.

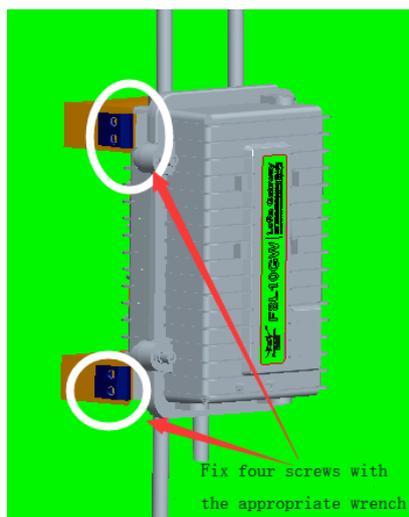

2.5 Pole-mounted Installation

1. Select the suitable pole with $\varnothing 70\sim 90\text{mm}$ diameter.

◆ *Requirement:*

1. *must be in an open area*
2. *make sure no shield within 5 meters*

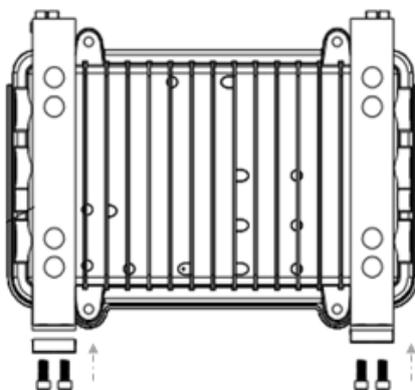

2. Put the clamp into the pole, fix the clamp in the pole with screws.

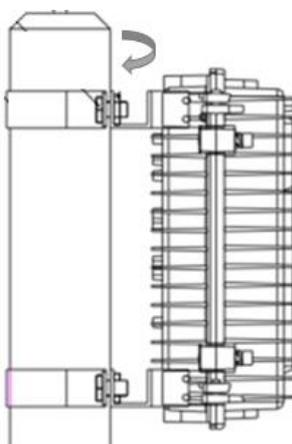

2.6 Antenna Installation

After F8L10GW is installed on the wall or pole, then install all fiberglass omnidirectional antennas (4G/WIFI/LoRa), make sure all antennas are tightened to get best signal.

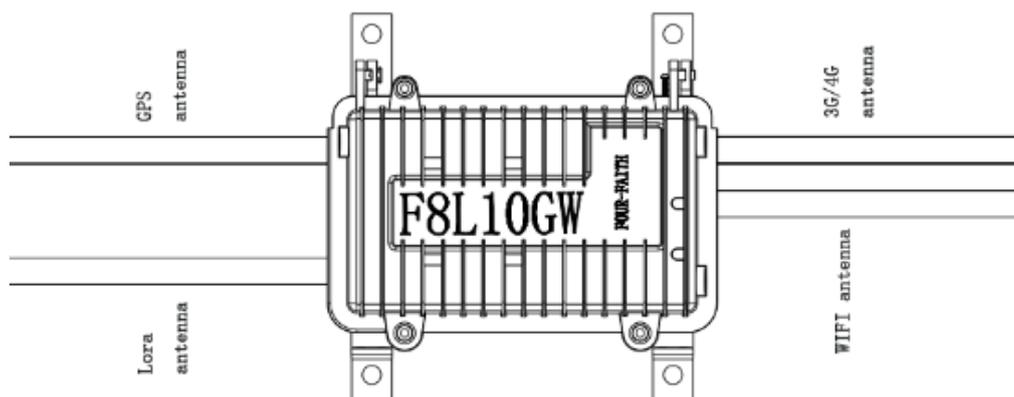

2.7 LED Indicators

The F8L10GW provides the following led indicators: including PWR, Sys, Online, SIM, LoRa, WAN, WIFI, Signal Strength. LED indicators description are as below:

LED	Indication	Status	Description
PWR	Power Status	Red light on	Power on
		Red light off	Power off
SYS	System Status	Yellow light flash	System work properly
		Yellow light off	System work improperly
WIFI	WIFI Status	Blue light on	WIFI on
		Blue light off	WIFI off
LORA	LoRa Status	Green light on	LoRa connect normal
		Green light off	LoRa connect abnormal
		Green light flash	LoRa data communicating
3G/4G Signal Strength	Signal 1/2/3	Turn on one light	Weak (less than -90db)
		Turn on two lights	Medium (-70db~-90db)
		Turn on three lights	Good (greater than -70db)
Online	Online Status	Green light on	Online
		Green light off	Offline

Chapter 3 Configuration

This chapter explains how to access to Web GUI of F8L10GW to complete device configuration.

3.1 Connect with the F8L10GW

Before configuration, you can connect the base station with a PC by WIFI or network cable.



- ◆ Connect the base station by **WIFI** (based on WIN10 operator system);

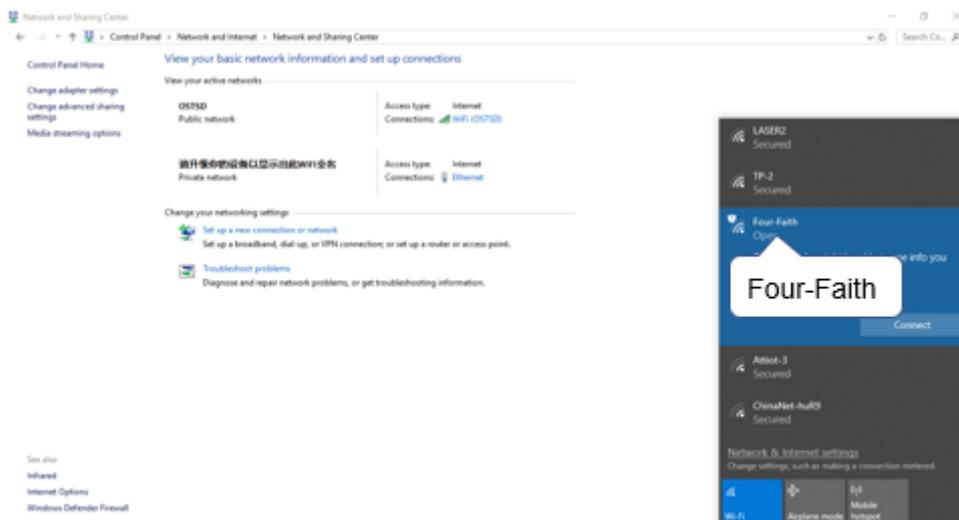

- 1 Connect the open hotspot "Four-Faith", and then click the "Connect" button to connect it.

◆ Connect the base station by **network cable** (based on WIN10 operator system)

1 Click the "Search Box" to search "Control Panel", and then open it

2 Find the "Network and Internet" item, and then click the "View network status and tasks"

3 Jump to this page, and click the "Ethernet"

4 Click "Properties" to enter into IP configure UI

5 Double click the "Internet Protocol Version 4(TCP/IPv4)" to configure IP information

6 Method 1: assign a static IP address manually within the subnet of F8L10GW

7 Method 2: click the "obtain an IP address automatically" to assign an IP address automatically

3.2 Access to configuration pages

Four-Faith LoRaWAN base station provides web configuration management. You can access to the configuration pages follow these steps:

1. Open browser (such as google, IE or others)
2. Input “192.168.1.1” in the search bar, and then it will enter into the configuration login page when connect F8L10GW correctly. If you are the first time configure the base station, please use the default settings by Four-Faith.

IP: 192.168.1.1

Username: admin

Password: admin

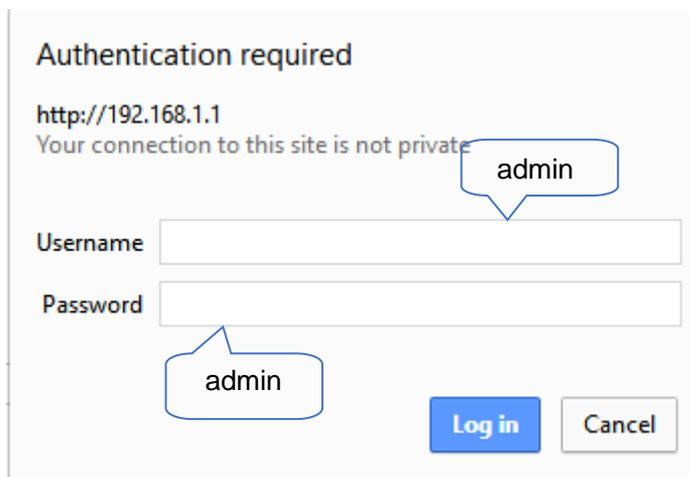

Authentication required

http://192.168.1.1

Your connection to this site is not private

admin

Username

Password

admin

Log in Cancel

3. Click the “**Log in**” button, and then you can access to device configuration management

3.3 Web Configuration

There are 11 main pages in the web configuration tool, include Settings, Wireless, Service, VPN, Security, Access Restrictions, NAT, QoS Settings, Applications, Management and Status.

3.3.1 Setup

In this module, you can according system directions to change the basic settings of F8L10GW.

Warning: Click the “Save” button only save current settings, you need click the “Apply Settings” to make it effect. And if you don’t want save changes, click the “Cancel Changes” will realize it.

3.3.1.1 Basic Setup

◆ WAN Setup

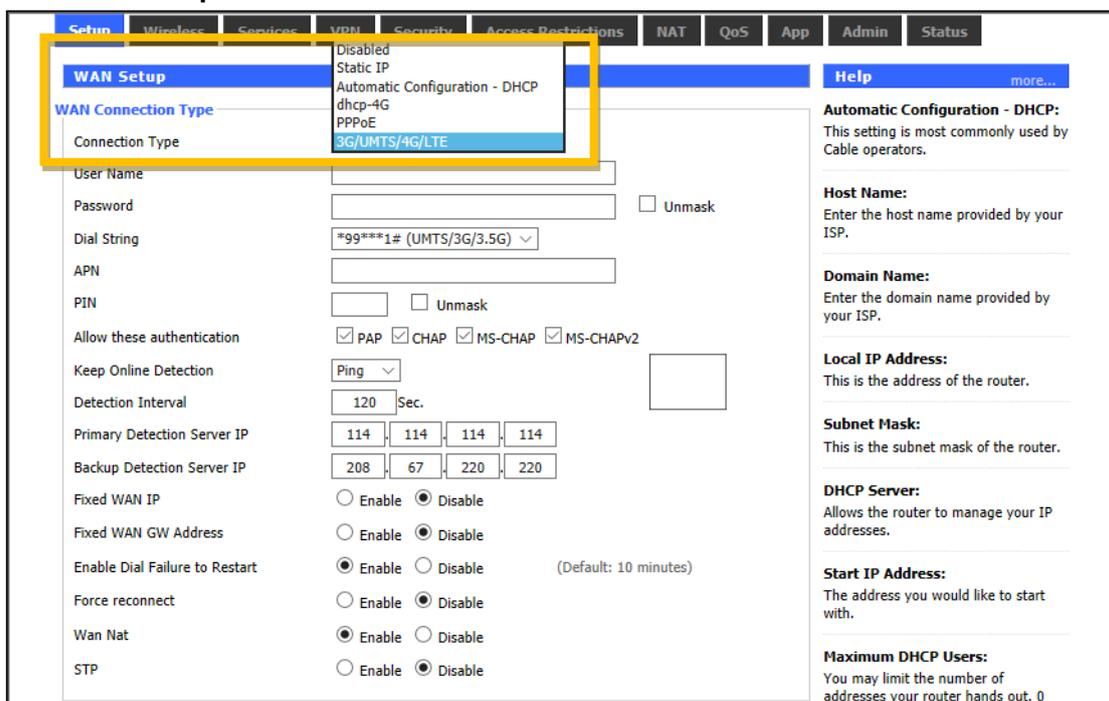

There are 6 WAN connection types, include: Disable, Static IP, Automatic Configuration - DHCP, DHCP-4G, PPPOE and 3G/UMTS/4G/LTE. And F8L10GW provides wired ethernet (only support LAN port) and dhcp-4G(default) connection types.

✚ Wired ethernet connection type

There have two configuration modes when you connect F8L10GW by network cable.

Mode 1: Static IP connection

Select the “**Static IP**” connection type, this page will auto refresh and then show the configuration parameters as follow:

Warning: you need prepare a public IP address.

WAN Connection Type

Connection Type	Static IP			
WAN IP Address	10	139	31	121
Subnet Mask	255	255	255	252
Gateway	10	139	31	122
Static DNS 1	0	0	0	0
Static DNS 2	0	0	0	0
Static DNS 3	0	0	0	0

Parameters	Option	Description
WAN IP Address	-	Public IP address
Subnet Mask	-	Subnet mask parameter
Gateway	-	Gateway parameter
Static DNS1	-	Static domain name server 1
Static DNS2	-	Static domain name server 2
Static DNS3	-	Static domain name server 3

Mode 2: Automatic Configuration – DHCP connection

Select the “Automatic Configuration - DHCP” connection type, this page will auto refresh and then show the configuration parameters as follow:

Warning: device will dynamic assignment the IP address to WAN port in this mode.

WAN Setup

WAN Connection Type

Connection Type	Automatic Configuration - DHCP
Wan Nat	<input checked="" type="radio"/> Enable <input type="radio"/> Disable
STP	<input type="radio"/> Enable <input checked="" type="radio"/> Disable

DHCP-4G connection type

Select the “dhcp-4G” connection type, this page will auto refresh and then show the configuration parameters as follow:

Warning: In this mode, the IP address of WAN port assigned by dhcp-4G (default).

WAN Connection Type

Connection Type	dhcp-4G	
User Name	<input type="text"/>	
Password	<input type="text"/>	<input type="checkbox"/> Unmask
APN	3gnet	
Fixed WAN IP	<input type="radio"/> Enable <input checked="" type="radio"/> Disable	
Allow these authentication	<input checked="" type="checkbox"/> PAP <input checked="" type="checkbox"/> CHAP	
Connection type	Auto	
PIN	<input type="text"/>	<input type="checkbox"/> Unmask
Keep Online Detection	Ping	
Detection Interval	120 Sec.	
Primary Detection Server IP	114 . 114 . 114 . 114	
Backup Detection Server IP	208 . 67 . 220 . 220	
Enable Dial Failure to Restart	<input checked="" type="radio"/> Enable <input type="radio"/> Disable	(Default: 10 minutes)
Wan Nat	<input checked="" type="radio"/> Enable <input type="radio"/> Disable	
STP	<input type="radio"/> Enable <input checked="" type="radio"/> Disable	

Parameters	Option	Description
User Name	-	Sim card account assigned by operator
Password	-	Sim card account assigned by operator
APN	-	APN number assigned by operator
Fixed WAN IP	Enable	Turn on fixed WAN IP address function. And then fill in the WAN IP address <small>Fixed WAN IP <input checked="" type="radio"/> Enable <input type="radio"/> Disable</small> <small>WAN IP Address <input type="text" value="0"/> <input type="text" value="0"/> <input type="text" value="0"/> <input type="text" value="0"/></small>
	Disable	Turn off this function
Allow these authentication	PAP	PAP authentication
	CHAP	CHAP authentication
Connection type	Auto	Automatically select operator network according deployment position
	Force-4G	Only works on 4G network
	Force-3G	Only works on 3G network
	Force-2G	Only works on 2G network
	Prefer-3G	3G network prefer select
	Prefer-2G	2G network prefer select
	Only 3G/2G	Support 2G/3G network
	Only 4G/3G/2G	Support 2G/3G/4G network
PIN	-	Sim card pin number
Keep Online Detection	None	Disable keep online detection function
	Ping	Send ping packets to detect whether connection is normal. In this mode, the "Detection Interval", "Primary Detection Server IP" and "Backup Detection Server IP"

		must be configured correctly
	Router	Use router method to detect whether connection is normal. In this mode, the “Detection Interval”, “Primary Detection Server IP” and “Backup Detection Server IP” must be configured correctly
Detection Interval	-	Time interval between two detection, unit is second
Primary Detection Server IP	-	Response the primary detection server IP address of F8L10GW when detect data packets online. This configuration item takes effect when “ Keep Online Detection ” set “ Ping ” or “ Router ” mode
Backup Detection Server IP	-	Response the backup detection server IP address of F8L10GW when detect data packets online. This configuration item takes effect when “ Keep Online Detection ” set “ Ping ” or “ Router ” mode
Enable Dial Failure to Restart	Enable	Turn on restart the device when dial-up failure function
	Disable	Turn off restart the device when dial-up failure function
Wan Nat	Enable	Turn on NAT forwarding of WAN port function
	Disable	Turn off NAT forwarding of WAN port function
STP	Enable	Turn on STP protocol. STP (Spanning Tree Protocol) can be applied to the loop network
	Disable	Turn off STP protocol

3.3.2 Wireless

You can configure WIFI parameters here. WIFI mainly used to upgrade device firmware.

Setup
Wireless
Services
VPN
Security
Access Restrictions
NAT
QoS
App
Admin
Status

Wireless Physical Interface w10 [2.4 GHz]
Help more...

Wireless Network Enable Disable

Physical Interface ra0 - SSID [Four-Faith] HWAddr [54:D0:B4:85:8F:3E]

Wireless Mode AP

Wireless Network Mode Mixed

Wireless Network Name (SSID) Four-Faith

Wireless Channel 11 - 2.462 GHz

Channel Width Auto

Wireless SSID Broadcast Enable Disable

Network Configuration Unbridged Bridged

Virtual Interfaces

Add

Save
Apply Settings
Cancel Changes

Wireless Network Mode:
 If you wish to exclude Wireless-G clients, choose *B-Only* mode. If you would like to disable wireless access, choose *Disable*.
Note : when changing wireless mode, some advanced parameters are susceptible to be modified ("Basic Rate" or "Frame Burst").

Parameters	Option	Description
Wireless Network	Enable	Turn on wifi
	Disable	Turn off wifi
Wireless Mode	AP	Convert wired network into wireless signal
	client	Receive wireless signal from other wireless routers and then convert it into wired network. PC only connect it through network cable
	ad-hoc	P2P connection, as virtual AP, and other PC can directly connect and share the network through it
	relay	Relay is a transmission path between two switching centers
	relay bridge	Wireless transmission can bridge the communication between two or more networks
Wireless Network Mode	Hybrid	Support 802.11b/g/n standard devices
	Bg-mix	Support 802.11b and 802.11g standard devices
	NG-mix	Support 802.11g and 802.11n standard devices
	B Only	Only support 802.11b standard devices
	G Only	Only support 802.11g standard devices
	Only N	Only support 802.11n standard devices
Wireless Network Name (SSID)	-	You can edit wireless network name here
Wireless Channel	-	There are 1-13 channels available. In the environment of multiple wireless devices, please try to avoid using the same channels as other devices
Channel	-	20MHZ and 40MHZ are available

Width											
Wireless SSID Broadcast	Enable	Broadcast SSID									
	Disable	Hide SSID									
Network Configuration	Bridged	In general, select bridged. The bridge is connected to F8L10GW									
	Unbridged	when no bridge is connected to F8L10GW, and the IP address needs to be manually configured: <div style="border: 1px solid black; padding: 5px; margin-top: 5px;"> <table style="width: 100%; border-collapse: collapse;"> <tr> <td style="padding: 2px;">Network Configuration</td> <td><input checked="" type="radio"/> Unbridged <input type="radio"/> Bridged</td> </tr> <tr> <td style="padding: 2px;">Multicast forwarding</td> <td><input type="radio"/> Enable <input checked="" type="radio"/> Disable</td> </tr> <tr> <td style="padding: 2px;">Masquerade / NAT</td> <td><input checked="" type="radio"/> Enable <input type="radio"/> Disable</td> </tr> <tr> <td style="padding: 2px;">IP Address</td> <td><input type="text" value="0"/> <input type="text" value="0"/> <input type="text" value="0"/> <input type="text" value="0"/></td> </tr> <tr> <td style="padding: 2px;">Subnet Mask</td> <td><input type="text" value="0"/> <input type="text" value="0"/> <input type="text" value="0"/> <input type="text" value="0"/></td> </tr> </table> </div>	Network Configuration	<input checked="" type="radio"/> Unbridged <input type="radio"/> Bridged	Multicast forwarding	<input type="radio"/> Enable <input checked="" type="radio"/> Disable	Masquerade / NAT	<input checked="" type="radio"/> Enable <input type="radio"/> Disable	IP Address	<input type="text" value="0"/> <input type="text" value="0"/> <input type="text" value="0"/> <input type="text" value="0"/>	Subnet Mask
Network Configuration	<input checked="" type="radio"/> Unbridged <input type="radio"/> Bridged										
Multicast forwarding	<input type="radio"/> Enable <input checked="" type="radio"/> Disable										
Masquerade / NAT	<input checked="" type="radio"/> Enable <input type="radio"/> Disable										
IP Address	<input type="text" value="0"/> <input type="text" value="0"/> <input type="text" value="0"/> <input type="text" value="0"/>										
Subnet Mask	<input type="text" value="0"/> <input type="text" value="0"/> <input type="text" value="0"/> <input type="text" value="0"/>										

Click the “Add” button in “Virtual Interfaces” bar to add virtual interface, as follow:

Virtual Interfaces ra1 SSID [ff_vap]

Wireless Network Name (SSID)

Wireless SSID Broadcast Enable Disable

AP Isolation Enable Disable

Network Configuration Unbridged Bridged

3.3.3 LoRaWAN Application

You can configure lora parameters of base station here.

Setup
Wireless
Services
VPN
Security
Access Restrictions
NAT
QoS
App
Admin
Status

LoRaWAN package forwarder

LoRaWAN Gateway Basic Config

LoRaWAN Enable Disable

Enable Connect Failure to Restart Enable Disable

config type

Server IP

serv_port_up

serv_port_down

LoRaWAN Gateway Advanced Config

LoRaWAN Enable Disable

LoRaWAN Gateway ID

forward_crc_valid Enable Disable

forward_crc_error Enable Disable

forward_crc_disabled Enable Disable

◆ LoRaWAN Gateway Basic Config

Parameters	Options	Description
LoRaWAN	Enable	Turn on lora
	Disable	Turn off lora
Enable Connect Failure to Restart	Enable	
	Disable	
Server IP	-	The IP address of LoRaWAN data service center
Serv_port_up	-	LoRaWAN data service center program uplink port. Value range is 0-65535 and the default value is 1700.
Serv_port_down	-	LoRaWAN data service center program downlink port. Value range is 0-65535 and the default value is 1700

◆ LoRaWAN Gateway Advanced Config

Parameters	Options	Description
LoRaWAN	Enable	Turn on lora
	Disable	Turn off lora
LoRaWAN Gateway ID	-	the unique identity of the base station, which the server can distinguish different LoRaWAN base station
Forward_crc_valid	Enable	Turn on CRC for validation (default)
	Disable	Turn off CRC for validation
Forward_crc_error	Enable	Turn on CRC for validation error function
	Disable	Turn off CRC for validation error function (default)
Forward_crc_disabled	Enable	Turn on CRC validation
	Disable	Turn off CRC validation (default)

3.3.4 Admin

3.3.4.1 Management

This page allows network administrators to manage specific F8L10GW functions to ensure access and security.

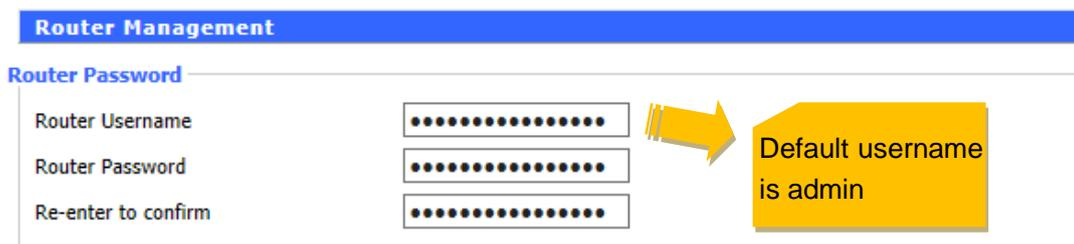

New password shall not exceed 32 characters length and shall not contain any space. Make sure the password is the same as the one you set, or the system will prompt an error.

We strongly recommend that modify the default password to ensure system security.

◆ **Web Access**

You can manage the base station by HTTP or HTTPS protocol, and if you select to disable this function, it should be root manually.

Also, you can enable or disable the information pages of F8L10GW, so that you can protect it by password (input correctly username and password to open it).

Web Access

Protocol HTTP HTTPS

Auto-Refresh (in seconds)

Enable Info Site Enable Disable

Info Site Password Protection Enabled

Parameters	Options	Description
Protocol	HTTP	Web access by http
	HTTPS	Web access by https
Auto-Refresh (in seconds)	-	The time interval for automatic refresh the web page. If you set 0, it means turn off this function
Enable Info Site	Enable	Enable display system information page before login
	Disable	Disable display system information page before login
Info Site Password Protection	Enabled	Enable the system information page password protection function
	None	Disable the system information page password protection function

◆ **Remote Access**

It allows remote manage the device through the internet.

Warning: If the remote access function is turn on, anyone who get the correctly IP address and password will change the device settings.

Remote Access

Web GUI Management Enable Disable

Use HTTPS

Web GUI Port (Default: 8088, Range: 1 - 65535)

Local Web GUI Port (Default: 80, Range: 1 - 65535)

SSH Management Enable Disable

SSH Remote Port (Default: 22, Range: 1 - 65535)

Telnet Management Enable Disable

Parameters	Options	Description
Web GUI Management	Enable	Enable remote web management function. If you don't check the https protocol, you can input http://xxx.xxx.xxx.xxx:8088 to remote manage F8L10GW, else you need input https://xxx.xxx.xxx.xxx:8088 (x means the access IP address, and 8088 means the web access port),
	Disable	Disable remote web management function
Use HTTPS	-	Whether using https protocol access device. It will take effect when you check it
Web GUI Port	-	Specify the web access port, default 8088
Local Web GUI Port	-	Specify the local access port, default 80
SSH Management	Enable	Turn on SSH remote management function. You can get more information about SSH daemon settings in service pages
	Disable	Turn off SSH remote management function
SSH Remote Port	-	Specify the SSH remote port, default 22
Telnet Management	Enable	Turn on telnet management function
	Disable	Turn off telnet management function

◆ **Cron**

Cron can execute the Linux commands what you plan. You can set the command lines or scripts in that.



Parameters	Options	Description
Cron	Enable	Turn on Cron server
	Disable	Turn off Cron server
Additional Cron Jobs	-	Linux command lines or scripts

◆ **Remote Management**

This function is used for server configurations with device platform, such as device monitoring platform, WIFI advertising system, device flow monitoring and so on. To get more details can contact with our technical support.

◆ **Firmware Upgrade**

Remote firmware upgrade configuration.

Firmware Upgrade

Firmware Upgrade	<input checked="" type="radio"/> Enable <input type="radio"/> Disable
Upgrade Server IP	<input type="text" value="42.121.16.56"/>
Upgrade Server Port	<input type="text" value="882"/> (Default: 882, Range: 1 - 65535)

Parameters	Options	Description
Firmware Upgrade	Enable	Turn on remote firmware upgrade function
	Disable	Turn off remote firmware upgrade function
Upgrade Server IP	-	Configure upgrade server IP address
Upgrade Server Port	-	Configure upgrade server port

3.3.4.2 Factory Defaults

Reset router settings

Restore Factory Defaults	<input type="radio"/> Yes <input checked="" type="radio"/> No
--------------------------	---------------------------------------------------------------

In this page, you can restore device configurations. If you select “**yes**” and then click the “**Apply Setting**” button, all configurations will be cleared and restored to factory settings.

3.3.4.3 Firmware Upgrade

Firmware Management

Firmware Upgrade

Please select a file to upgrade

WARNING

**Upgrading firmware may take a few minutes.
Do not turn off the power or press the reset button!**

New firmware version can be found in en.four-faith.com, you can download it free, and then loading it into F8L10GW. If the device can work normally, there is no need download and upgrade new firmware version, unless new firmware version includes what new features you want.

Click the “**browse**” button and then choose the firmware file and then click the “**upgrade**” button, the device starting upgrade. It may take a few minutes, please don’t power off or reset the device.

Warning: It may be lost configurations when upgrade firmware, so you need backup

current configurations before upgrade it.

3.3.4.4 Backup

This module is used to backup or restore the device configuration file.

Backup Configuration

Backup Settings

Click the "Backup" button to download the configuration backup file to your computer.

Restore Configuration

Restore Settings

Please select a file to restore

WARNING

**Only upload files backed up using this firmware and from the same model of router.
Do not upload any files that were not created by this interface!**

If you want to backup configuration file, please click the “**Backup**” button and then follow the system directions step by step.

If you want to restore configuration file, please click the “**Browse**” button select the backup configuration file and then follow the system directions step by step. And click the “**Restore**” button to upload it.

3.3.5 Status

3.3.5.1 Router

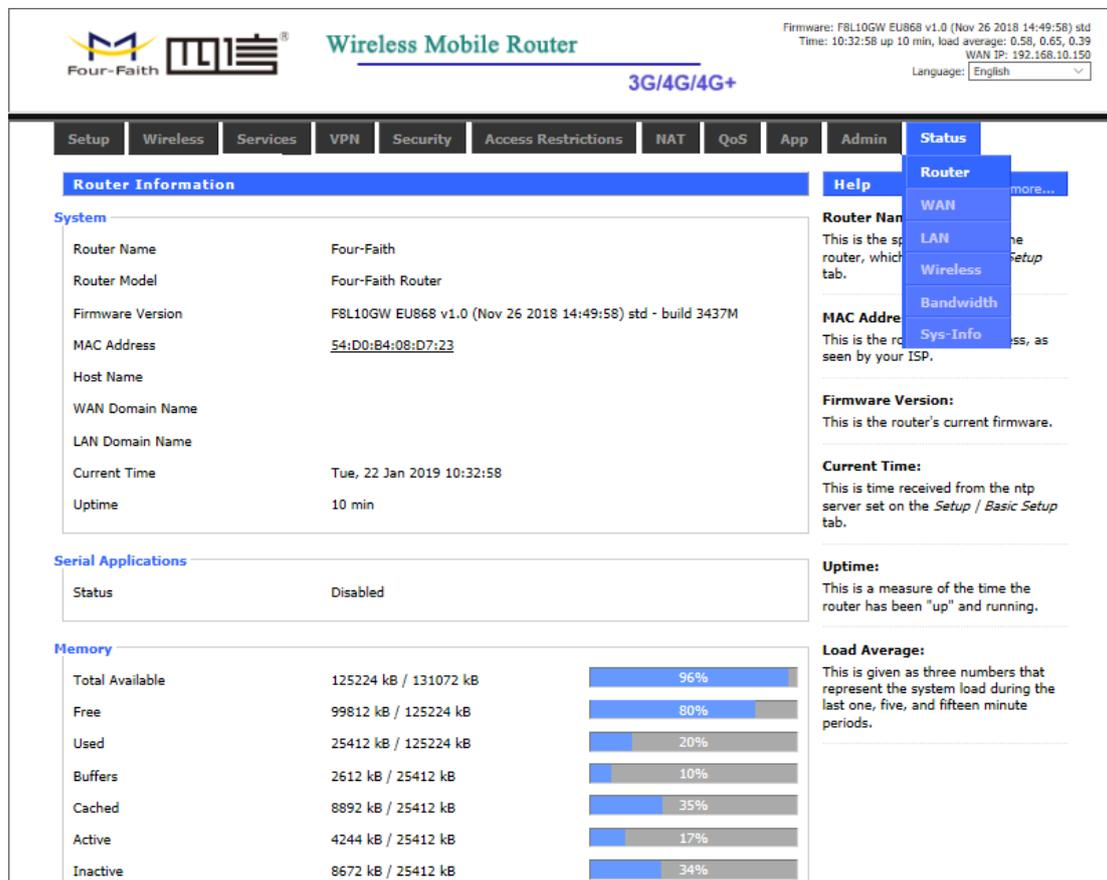

Router Information

Router Name	Four-Faith
Router Model	Four-Faith Router
Firmware Version	F8L10GW EU868 v1.0 (Nov 26 2018 14:49:58) std - build 3437M
MAC Address	54:D0:B4:08:D7:23
Host Name	
WAN Domain Name	
LAN Domain Name	
Current Time	Tue, 22 Jan 2019 10:32:58
Uptime	10 min

Serial Applications

Status	Disabled
--------	----------

Memory

Total Available	125224 kB / 131072 kB	96%
Free	99812 kB / 125224 kB	80%
Used	25412 kB / 125224 kB	20%
Buffers	2612 kB / 25412 kB	10%
Cached	8892 kB / 25412 kB	35%
Active	4244 kB / 25412 kB	17%
Inactive	8672 kB / 25412 kB	34%

Item	Field	Description
System	Router Name	Show the router name of base station
	Router Model	Show the router model name of base station
	Firmware version	Show the current firmware version of base station
	MAC Address	Show the MAC address of base station
	Host Name	Show the host name of base station
	WAN Domain Name	Show the WAN port domain name of base station
	LAN Domain Name	Show the LAN port domain name of base station
	Current Time	Show the system current time of base station
	Uptime	Show the system run time of base station
Serial Application	Status	Show the serial application status of base station
Memory	Total Available	Show the available memory size of base station
	Free	Show the free memory size of base station
	Used	Show the used memory size of base station

	Buffers	Show the available buffer of base station
	Cached	Show the number of cache data
	Active	Show the active memory size of base station
	Inactive	Show the inactive memory size of base station
Network	IP Filter Max Connections	Show the IP Filter connections of base station
	Active IP Connections	Show the active IP connections of base station, if you click this link, it will show all active IP details

3.3.5.2 WAN



Wireless Mobile Router

3G/4G/4G+

Firmware: F8L10GW EU868 v1.0 (Nov 26 2018 14:49:58) std
 Time: 11:26:44 up 1:04, load average: 0.63, 0.66, 0.56
 WAN IP: 192.168.10.150
 Language: English

Setup

Wireless

Services

VPN

Security

Access Restrictions

NAT

QoS

App

Admin

Status

Help

Router

WAN

LAN

Wireless

Bandwidth

Sys-Info

WAN

Configuration Type

Connection Type	Static
Connection Uptime	1:04:10
IP Address	192.168.10.150
Subnet Mask	255.255.255.0
Gateway	192.168.10.1
DNS 1	114.114.114.114
DNS 2	
DNS 3	

Traffic

Total Traffic

Incoming (MBytes)	0
Outgoing (MBytes)	0

Traffic by Month

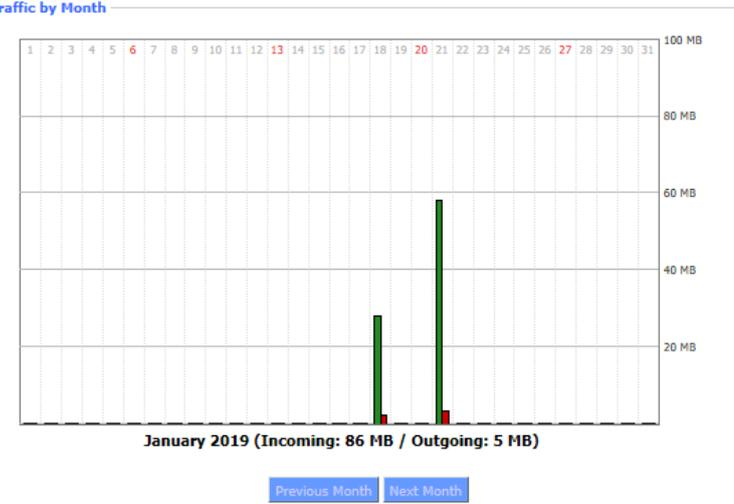

January 2019 (Incoming: 86 MB / Outgoing: 5 MB)

[Previous Month](#)
[Next Month](#)

Data Administration

[Backup](#)
[Restore](#)
[Delete](#)

Auto-Refresh is On

Help

Router

WAN

LAN

Wireless

Bandwidth

Sys-Info

Total Traffic:
This shows your router's Internet traffic since last reboot.

Traffic by Month:
This shows your router's Internet traffic by month. Drag the mouse over graph to see daily data. Data is stored in nvram.

F8L10GW-V3.0.1

en.four-faith.com

Page 30 of 31

Item	Parameters	Description
Configuration Type	Configuration Type	Show current connect type of base station
	Connection Uptime	Show current duration online of base station
	IP Address	Show the IP address of WAN port
	Subnet Mask	Show the subnet mask of WAN port
	Gateway	Show the gateway of WAN port
	DNS1	Show the DNS1 of WAN port
	DNS2	Show the DNS2 of WAN port
Total Traffic	DNS3	Show the DNS3 of WAN port
	Incoming	Show the incoming total traffic
Data Administration	Outgoing	Show the outgoing total traffic
	Backup	Backup the data administration configuration
	Restore	Restore the data administration configuration
	Delete	Delete the data administration configuration

3.3.5.3 System Info

LoRaWAN

Server status	connected
Mac	54D0B4FFFE861886
GPS status	vaild
Longitude	118.047160
Latitude	24.610998
Altitude	91

Item	Parameters	Description
Server status	-	Show the LoRaWAN server connection status
Mac	-	The device Mac address
GPS status	-	Show the GPS status
Longitude	-	Show current longitude of F8L10GW
Latitude	-	Show current latitude of F8L10GW
Altitude	-	Show current altitude of F8L10GW