

Antenna Overview

Version 3.3
2013/12/16



Contents

ANT-Ceiling-Mimo-2G for 802.11n AP	Order No.: 5510000209.....	3
ANT-Omni-4-dual	Order No.: 600529.....	4
ANT-Omni-vehicle-1.2m	Order No.: 600519	5
ANT-RTNC.S-O-STD-2+5G	Order No.: 600487.....	6
ANT-Omni-5-2G-1.2m	Order No.: 600518.....	7
ANT-Omni-8-Dual	Order No.: 5510000234	8
ANT-N-11-5G-dualpol for 802.11n Bridge Links	Order number: 5500001542	9
ANT-N-20-5G-dualpol for 802.11n Bridge Links	Order number: 5500000551	10
WLAN-Bridgelink-Bundle	Order No.: 5510000226	11
WLAN-Outdoor Bridgelink-Bundle	Order No.: 5510000271	12
ANT-D-8/11-dual-0.2m	Order No.: 600512.....	13
ANT-N-D-13/15-dual	Order No.: 600513.....	14
ACC-EMP-N-dual	Order No.: 600499.....	15
Low-Loss antenna cables.....		16

ANT-Ceiling-Mimo-2G for 802.11n AP Order No.: 5510000209

This antenna can be used in suspended ceilings for 2x3 MIMO Access Points (i.e. W1002n) as ceiling antenna that fits perfect in office areas. The antenna contains two antenna systems there are 90° twisted again each other and allows the transmission of two streams. Two streams allows up to 300Mbit/s PHY rate. Mounted at the ceiling of a room the antenna directed the signal under approx. 60° downwards. In combination with multi-reflexions at the walls and the ground the coverage is similar or better than the coverage of a omni directional antenna. The antenna is shipped together with two cables and fits without any additional adaptors to the W1002n/Wx0x40n, W1x065n.

Features:

Item	ANT-Ceiling-Mimo-2G
Order No.	Indoor MIMO Ceiling Antenna
Frequency range	5510000209
Range (2,4 GHz)	2400 MHz –2500 MHz
Polarization	Indoor 40-60 m
Isolation between both systems	Dual-Linear +/- 45°
VSWR	15 dB
Gain	1,5 : 1
3 dB horizontal beam angle	9 - 10 dBi
3 dB vertical beam angle	360 °
Connector	62 - 71°
Cable SMA to RTNC (i.e. W1002n)	2 x SMA jack
	Shipment is including two cables with 2m length.
	Approx. 2dB attenuation.
Weight, Dimensions	Approx. 130 g, 13,3 cm x 6,5 cm
Color	Light gray
Operation/Storage Temperature	-10 °C to +55 °C
IP safety class	IP20 for Indoor usage

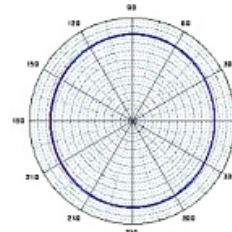
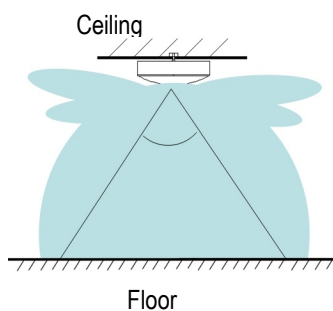
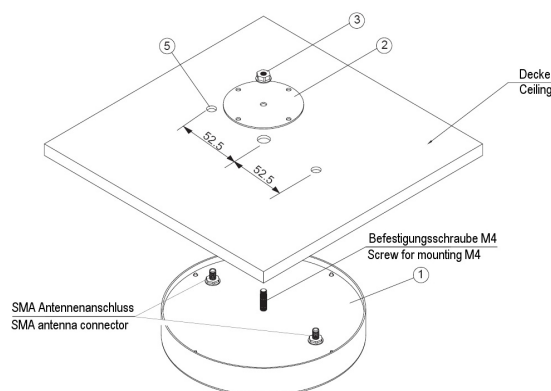

Radiation pattern horizontal

ANT-Omni-4-dual

Order No.: 600529

Description

This antenna features omni directional radiation and has a gain of 4 dBi. The antenna is equipped with an N jack and always requires an adapter cable from N to RTNC or RSMA, depending on the device to which it is connected. Due to its special characteristics, it can be used in either of the two frequency bands by merely switching the frequency at the W1002n or WI-Series. This means that the user can freely select the frequency band he or she prefers, e.g. if there are interfering applications in the 2.4 GHz band. It can be used in suspended ceilings and is thus suitable for unobtrusive WLAN supply within buildings. It comes with two screws and anchors for fixation.

Features:

Item	ANT-Omni-4-dual
Order No.	600529
Frequency range	2400 - 5875 MHz
Appropriate cable from N to RTNC (Wx000)	CAB-RTNC-N-0.5m, No.: 600507
Appropriate cable from N to RSMA	CAB-RSMA-N-0,5m, No.: 600530
Adapter from RTNC to RSMA	CAB-RSMA-RTNC—0.2m, No.: 600505
Range (2,4 GHz)	Line of sight approx. 400 m, indoors approx. 40 m
Polarization	Linear, vertical
VSWR	1.7
Gain	>4 dBi
Connector	N jack
Weight, dimensions	approx. 300 g, 8.6 cm x 4.3 cm
Color	Light gray, RAL 7035
Operating temperature	-40 °C to +80 °C
Storage temperature	-40 °C to +80 °C
Wind load	10 N at 160 km/h (100 mph)

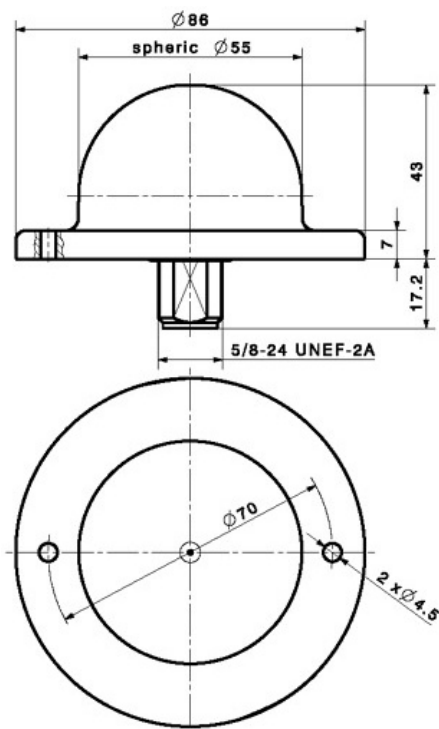

Radiation Pattern

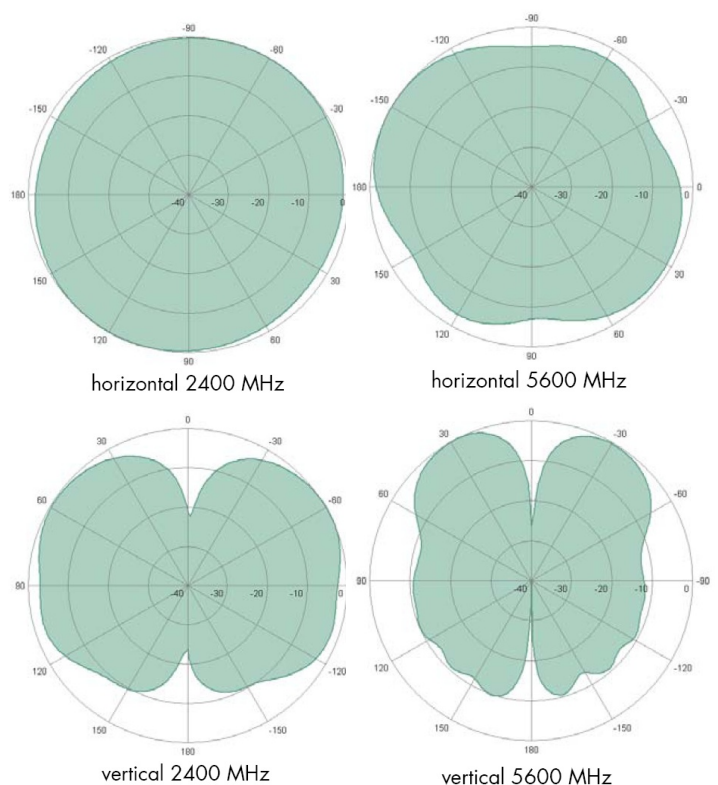

ANT-Omni-vehicle-1.2m

Order No.: 600519

Description:

This antenna features omni directional radiation and has a gain of 5 dBi. It is particularly suitable for vehicle mounting. Using its 1.2 m cable, it can be connected directly. If required, the cable can be extended with optionally available RTNC cables. With the help of an adapter to RSMA, this antenna can also be operated at devices with RSMA jack. For optimum operation, this antenna requires a metallic surface of at least 40 cm x 40 cm, such as a vehicle roof. This antenna is waterproof and can therefore be used both indoors and outdoors.

Features:

Item	ANT-Omni-vehicle-1.2m
Order No.	600519
Frequency band	2400 MHz –2500 MHz
Polarization	Linear, vertical
VSWR	< 1.5
Gain	4 dBi (cable loss included)
Cable length	1.2 m
Connector	RTNC plug
Hole diameter	12mm
Height	95mm
Depth	Approx. 15mm
Color	Black

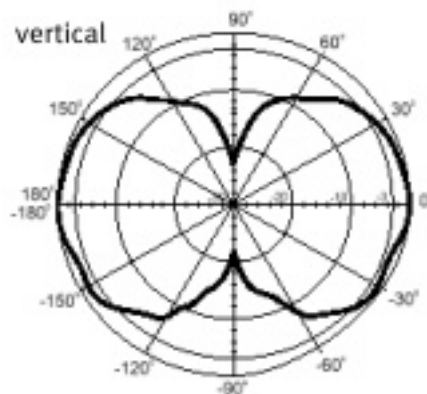

ANT-RTNC.S-O-STD-2+5G

Order No.: 600487

Description:

This antenna is a replacement standard antenna for devices with RTNC connector, such as W1002n or Wi-Serie,. It is swivel-mounted and can easily be adjusted to the desired position.

Features:

Item	ANT-RTNC.S-O-STD-2+5G
Order No.	600487
Range	Line of sight approx. 300 m, indoors approx. 30 m
Frequency band	2400 MHz –2500 MHz / 4900 MHZ -5900 MHZ
VSWR	< 2.0
Gain	1.7 dBi
Connector	RTNC plug
Dimensions	approx. 14.5 cm x 1.5 cm
Color	Black
Operating temperature	-20 °C to +65 °C
Storage temperature	-30 °C to +75 °C

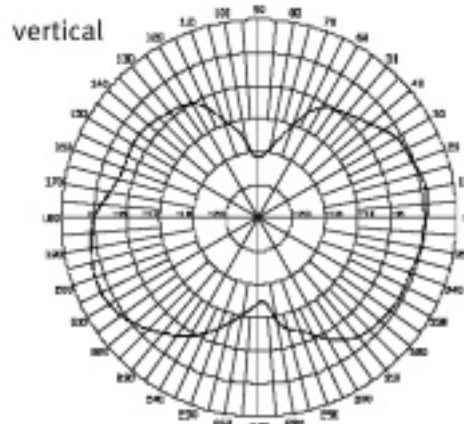
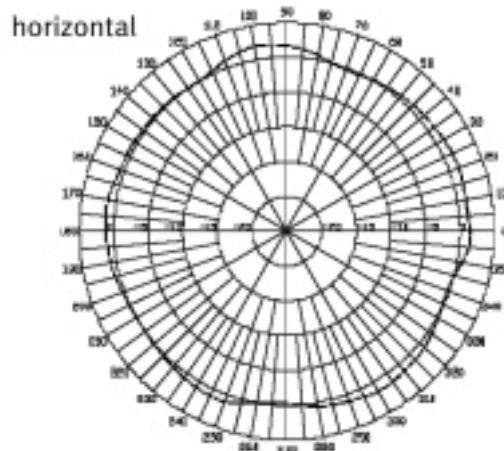
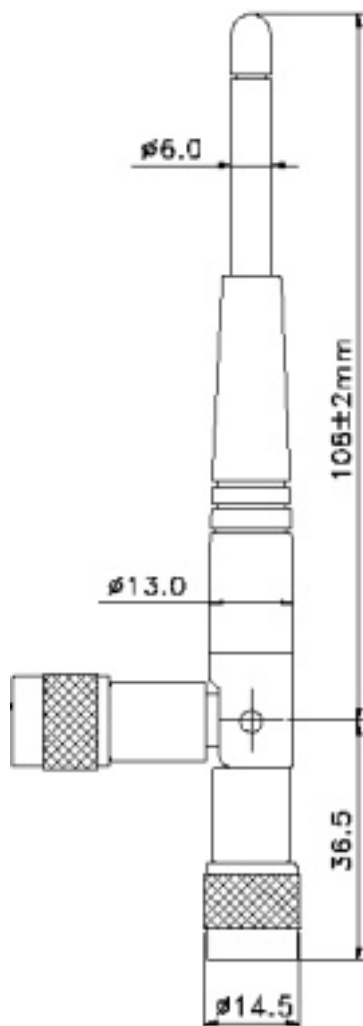

ANT-Omni-5-2G-1.2m

Order No.: 600518

Description:

This antenna features omnidirectional radiation and has a gain of 5 dBi. The antenna is equipped with a cable length of 1.2 m and can thus be positioned at some distance from the access point in order to improve the transmission and reception properties and to make optimum use of the antenna diversity. If the 1.2 m cable is not long enough, it can be extended with optionally available RTNC cables. With the help of an adapter to RSMA, this antenna can also be operated at devices with RSMA jack. This antenna is waterproof and can therefore be used both indoors and outdoors, e.g. to service an outdoor area. The scope of delivery includes mounting kits for wall, mast, and window mounting.

Features:

Item	ANT-Omni-5-2G-1.2m
Order No.	600518
Frequency band	2400 MHz –2500 MHz
Range	Line of sight approx. 500 m, indoors approx. 40 m
Polarization	Linear, vertical
VSWR	< 2.0
Gain	4 dBi (cable loss included)
Cable length	1.2 m
Connector	RTNC plug
Weight, dimensions	approx. 800 g, 33 cm x 1.9 cm
Color	White
Operating temperature	-40 °C to +80 °C
Storage temperature	-40 °C to +80 °C

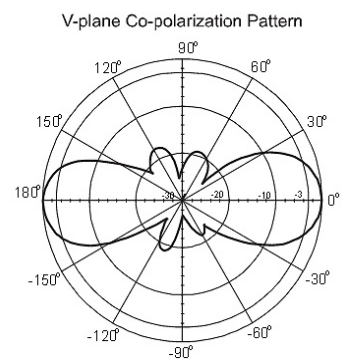
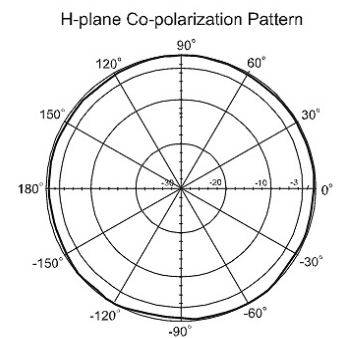
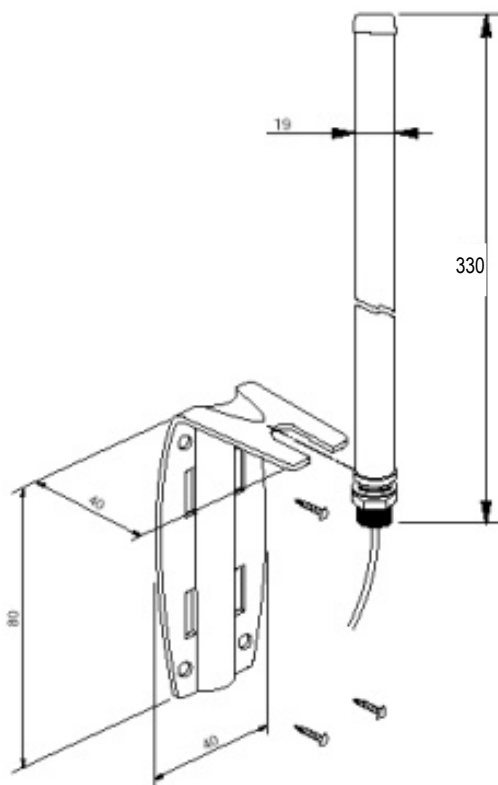

ANT-Omni-8-Dual

Order No.: 5510000234

Description:

This antenna is an Indoor/Outdoor antenna for 2.4 GHz and 5 GHz. The antenna is suitable for smaller distances up to several hundred meters, depending on the desired data rate. It must be used with the over voltage protector ACC-EMP-N-dual.

Frequency range	2400-2500 MHz 4900-5470 MHz	Connector	N female
Gain	8dBi	Survival wind speed	216 km/h
VSWR	2,0:1 max	Temperature	-40°C bis + 70°C
Impedance	50 Ohm	Humidity	95%@25°C
Polarization	Linear vertical	Color	White gray
HPBW / horizontal	360°	Material	ABS, UV resistant
HPBW / vertical	15°	Weight	350g
Power Handling	5W (CW)	Dimensions	81 * 78 * 870 mm



H-plane, Max. Gain = 8dBi, Omni

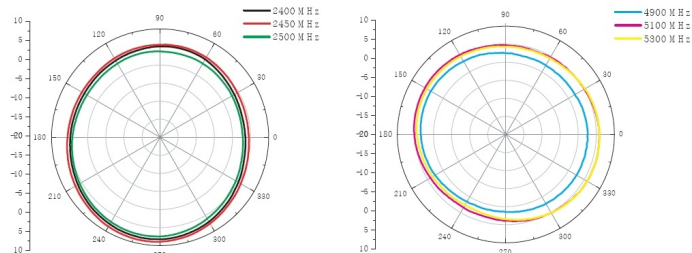

E-plane, Max. Gain = 8dBi, -3dB
Beamwidth=15 Grad

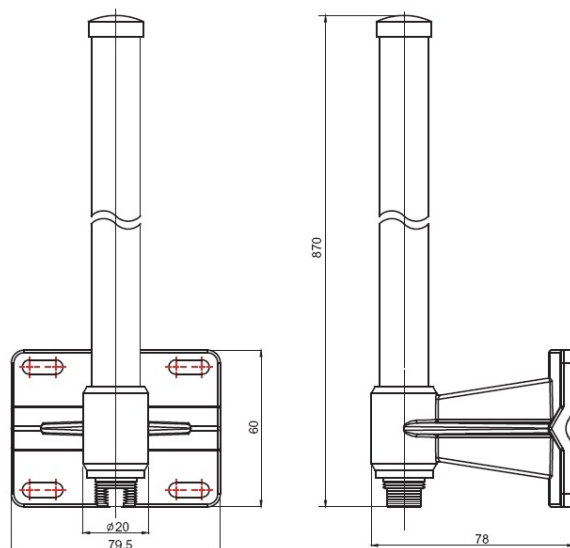
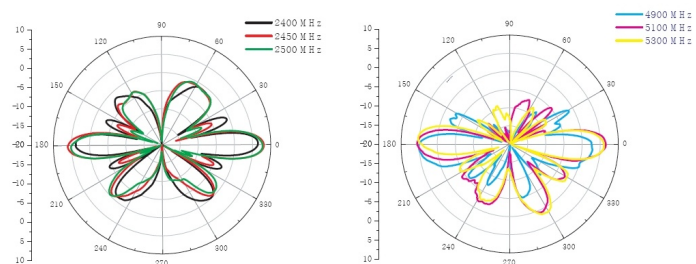

ANT-N-11-5G-dualpol for 802.11n Bridge Links Order number: 5500001542

Description:

This 5 GHz Dual Polarization antenna is suitable for directional links in combination with 802.11n units there transmit two streams. The antenna contains two independent antenna systems, the polarization of these systems are 90° twisted against each other. It has a gain of 11-12 dBi and a beam angle of 34°, which permits targeted transmission. The antenna is very small and fits perfectly for various applications, the performance is good enough for short and medium distances. The antenna has two N jack connectors. Shipment includes wall mounting and a simplified pole mounting.

Features:

Item	ANT-N-11-5G-dualpol
Order No.	5500001542
Frequency band	5150 - 5875 MHz
Polarization	Linear, vertical and horizontal
Gain	11-12 dBi
3 dB horizontal beam angle	36°
3 dB vertical beam angle	34°
Front to back ratio	> 20 dB
Max. power	6 W (CW) at 25 °C
Weight/Dimensions	236g / 122 x 122 x 47 mm
Mounting	Wall mounting or pole mounting by hose clamp
Connector/Cable	N-Jack / RG223, 150 mm
Color	Light gray
Material	Plastic
Operating temperature	-40 °C bis +70 °C
Storage temperature	-40 °C bis +70 °C
IP safety class	IP65

Remark: This antenna has two antenna sockets, therefore you need two sets of cable and surge adaptors.



Port 1

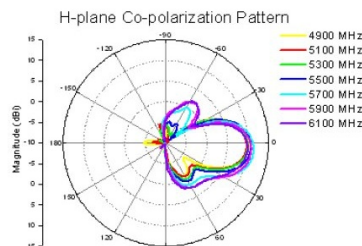

Port 2

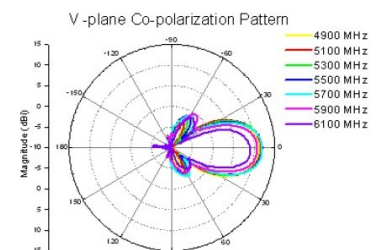
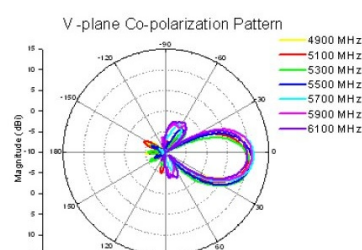
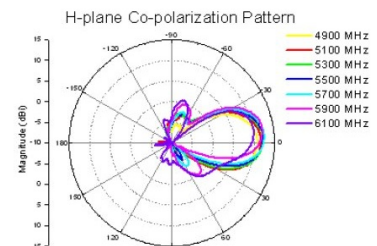

ANT-N-20-5G-dualpol for 802.11n Bridge Links

Order number: 5500000551

Description:

This 5 GHz Dual Polarization antenna is suitable for directional links in combination with 802.11n units there transmit two streams. The antenna contain two independent antenna systems, the polarization of these systems are 90° twisted again each other. It has a gain of 20 dBi and a beam angle of 10°, which permits targeted transmission. At the full transmission rate of 300 Mbps PHY rate, up to 800 m can be covered, and at a rate of 150 Mbps, up to approximately 2 km can be covered. Due to its compact and flat shape, it is unobtrusive and easy-to-mount. The antenna has two N jack and can thus be connected to a W1002n or Wi-Series by using the particularly low-loss cables. Shipment is including pole and wall mounting.

Features:

Item	ANT-N-20-5G-dualpol
Order No.	5500000551
Frequency band	5100 - 5900 MHz
Polarization	Linear, vertical and horizontal
Gain	20,6 dBi at 5100 MHz, 19,5 dBi at 5500 MHz 19 dBi at 5900 MHz
3 dB horizontal beam angle	10°
3 dB vertical beam angle	10°
Front to back ratio	> 30 dB
Max. power	6 W (CW) at 25 °C
Side-lobe suppression	ETSI EN 302 085 Range 1 TS1 - TS3
Weight, dimensions	1,5 kg, 320 x 320 x 20 mm
Pole Mounting	Suitable for poles from 48-80 mm Ø
Color	Light gray
Material	Plastic
Operating temperature	-40 °C bis +70 °C
Storage temperature	-40 °C bis +70 °C
IP safety class	IP 67

Remark: This antenna has two antenna sockets, therefore you need two sets of cable and surge adaptors.

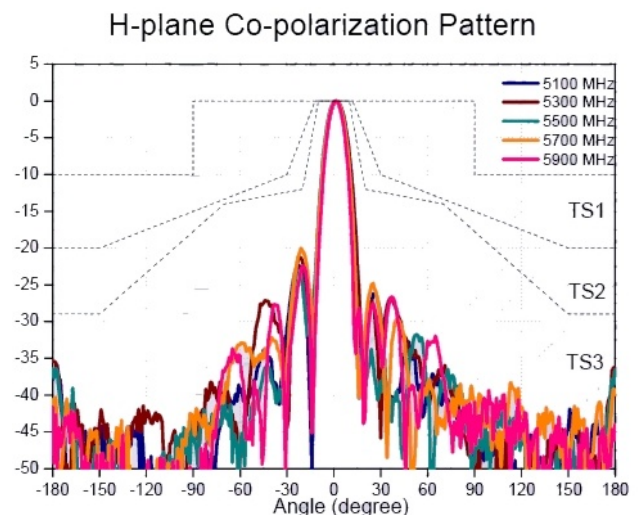

WLAN-Bridgelink-Bundle Order No.: 5510000226

Description: The WLAN Bridge Link Bundle “Out-of-the-Box” is designed for wireless wireless bridging of radio links in outdoor environments. The Bundle contain all required components to setup a radio link by using the new 802.11n technology. The usage of the components is sense full for radio links with up to 6 km distance.

The follow components are contains:

Quantity	Order No.	Description
2	5510000165	bintec W1002n (Indoor usage)
4	600507	0,5m RTNC plug N plug LMR400
4	600499	Surge Arrester N plug N jack
4	5500000847	6m N plug N jack LMR400
2	5500000551	ANT-N-20-5G Dual Polarization



In case of free line of sight the following results are expected by using the following configuration.

Distance	PHY Rate	Configuration of the Access Point				Allowed EIRP	Minimum antenna height
		Operation Band	Number of Spatial Streams	Bandwidth	Transmit Power		
0,5 km	300 Mbit/s	5 GHz Outdoor	2	40 MHz	16 dBm	1000 mW	2 m
1 km	180 Mbit/s	5 GHz Outdoor	2	40 MHz	14 dBm	1000 mW	3 m
2 km	120 Mbit/s	5 GHz Outdoor	2	40 MHz	11 dBm	1000 mW	4 m
4 km	30 Mbit/s	5 GHz Outdoor	2	40 MHz	11 dBm	1000 mW	4,5 m
6 km	14,4 Mbit/s	5 GHz Outdoor	2	20 MHz	11 dBm	1000 mW	6 m

Hints to improve the operating distance:

- Use shorter cables, to reduce the cable lost
- Use a antenna with higher gain
- Select 20 MHz bandwidth instead 40 MHz, or use only one stream.
-

Hints for installation:

- The link must be free from any obstacles (free line of sight). If necessary a different location must be used or the antenna height must be increased.
- The antenna connectors of the Access Point ANT1 and ANT2 are connected to the antenna. It makes no difference which antenna socket is used. The antenna connector ANT3 of the AP are not used for these application.
- The antenna or rather the antenna pole must be connected with 16 mm² CU or more to the potential equalisation. The Surge Arrester protect the AP and must connected to the grounding of the building with 1,5 mm² CU or more. The Surge Arrester must be inserted in both antenna cables, usually close to the place there the antenna cable leaving the building. In some cases it is advisable to consult a specialist for lightning protection.

WLAN-Outdoor Bridgelink-Bundle Order No.: 5510000271

The WLAN Outdoor Bridge Link Bundle “Out-of-the-Box” is designed for wireless bridging of radio links in outdoor environments. The bundle contains all required components to setup a radio link by using the new 802.11n technology. This outdoor bundle contains two bintec WI1065n devices, which can be mounted directly at the antenna pole. The WI1065n access points are water protected and allow operation in temperature ranges between -25° C and +65° C.

The bundle contains also two PoE adapters, which enables power supply over network cable. The dual polarization antennas are transmitting the data over two streams, what leads to higher performance of the system. The WLAN Outdoor Bridgelink Bundle is intended to build radio links up to 8 km distance.



The bundle contains following components:

Quantity	Order No.	Description
2	5010590013	bintec WI1065n
2	5500000551	ANT-N-20-5G Dual Polarization
4	600507	0,5m RTNC plug N plug LMR400
4	600499	Surge Arrester N plug N jack
2	5020591700	Pole mounting WI-65 Series
2	600258	PoE Injector

In case of free line of sight the results below can be expected by using the following configuration:

Distance	PHY rate	Configuration of the Access Point				Allowed EIRP	Minimum antenna height
		Operation Band	Number of Spatial Streams	Bandwidth	Transmit Power		
0,6 km	300 Mbit/s	5 GHz Outdoor	2	40 MHz	14 dBm	1000 mW	2 m
1,5 km	180 Mbit/s	5 GHz Outdoor	2	40 MHz	11 dBm	1000 mW	3 m
2,5 km	120 Mbit/s	5 GHz Outdoor	2	40 MHz	9 dBm	1000 mW	4 m
5 km	60 Mbit/s	5 GHz Outdoor	2	40 MHz	9 dBm	1000 mW	5,5 m
8,5 km	14,4 Mbit/s	5 GHz Outdoor	2	20 MHz	9 dBm	1000 mW	8 m

Hints to improve the operating distance:

- Use a antenna with higher gain
- Select 20 MHz bandwidth instead 40 MHz, or use only one stream.
-

Hints for installation:

- The link must be free from any obstacles (free line of sight). If necessary a different location must be used or the antenna height must be increased.
- The antenna connectors of the Access Point ANT1 and ANT2 are connected to the antenna. It makes no difference which antenna socket is used. The antenna connector ANT3 of the AP are not used for these application.
- The antenna or rather the antenna pole must be connected with 16 mm² CU or more to the potential equalisation. The Surge Arrester protect the AP and must connected to the grounding of the building with 1,5 mm² CU or more. The Surge Arrester must be inserted in both antenna cables. In some cases it is advisable to consult a specialist for lightning protection.

ANT-D-8/11-dual-0.2m

Order No.: 600512

Description:

This dual-band antenna is mainly suited for indoors and directional links. It can be used e.g. for corridors, tunnels or outdoor links of up to a few hundred meters. It is very small and light and can be mounted on walls, masts, and glass surfaces, such as windows, using various mounting materials. At the full transmission rate of 54 Mbps, up to 100 m can be covered in the 5 GHz frequency band, and 500 m using the 2.4 GHz band, (if an identical antenna is used on the opposite side, with overvoltage protector and 1 m cable). At lower data rates, distances of up to 1 km can be covered. Due to its special characteristics, it can be used in either of the two frequency bands by merely switching the frequency at the W1002n or Wi-Series. This means that the user can freely select the frequency band he or she prefers, e.g. if there are interfering applications in the 2.4 GHz band. The antenna has an SMA jack and a 20 cm adapter cable from SMA to RTNC. It can thus be connected to a W1002n or the WI series and operated next to this device.

Features:

Item	ANT-D-8/11-dual-0.2m	
Order No.	600512	
Range	Depending on data rate and frequency, approx 700 m line of sight	
Frequency band	2400 MHz –2500 MHz	4900 MHz - 5875 MHz
Polarization	Linear, vertical	Linear, vertical
Gain	8.5 dBi	10.5 dBi
VSWR	< 2.0	< 2.0
HPBW / horizontal	58°	45°
HPBW / vertical	55°	45°
Front-to-back ratio	15 dB	
Tilt angle	0°	
Power consumption	10 W (cw)	
Impedance	50 Ohms	
Connector	R-TNC plug (antenna: SMA jack; with 20 cm cable ULA198 SMA plug →R-TNC plug)	
Weight, dimensions	120 g, 114 x 124 x 40 mm	
Color	Gray	
Material	ABS, UV-resistant	
Operating temperature	-40 °C to +80 °C	
Humidity	95 % @ 25 °C	

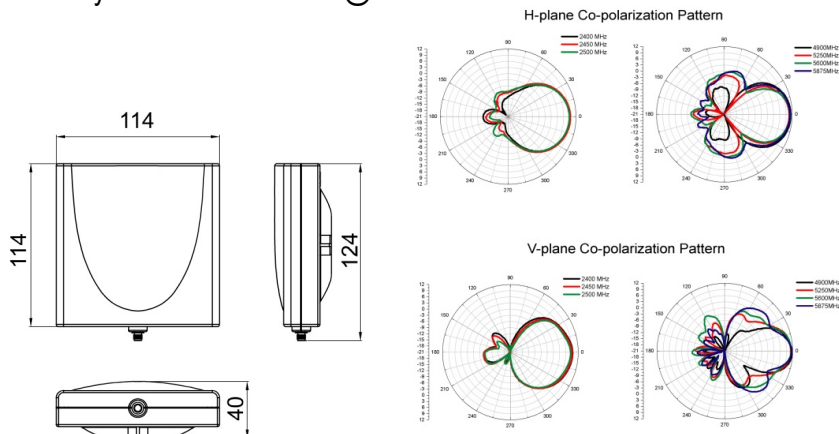

ANT-N-D-13/15-dual

Order No.: 600513

Description:

This antenna is a component of an antenna solution for 2.4 GHz and 5 GHz point-to-point connections for coupling sites via WLAN. Due to its special characteristics, it can be used in either of the two frequency bands by merely switching the frequency at the W1002n or the WI series. This means that the user can freely select the frequency band he or she prefers, e.g. if there are interfering applications in the 2.4 GHz band. The antenna is small and light and thus suitable for smaller distances of approx. 0.5 to 1 km, depending on the desired data rate and frequency band.

Features:

Item	ANT-N-D-13/15-dual	
Order No.	600513	
Range	Please refer to the Solution Sheet for outdoor antenna solutions	
Frequency band	2400 MHz –2500 MHz	4900 MHz - 5875 MHz
Gain	13.5 dBi	15.5 dBi
VSWR	< 2.0	< 2.0
Polarization	Linear, vertical	
HPBW / horizontal	30°	15°
HPBW / vertical	30°	15°
Front-to-back ratio	15 dB	
Tilt angle	0°	
Power consumption	10 W (cw)	
Impedance	50 Ohms	
Connector	N jack	
Weight, dimensions	407 g, 200 x 218 x 50 mm	
Color	Light gray	
Material	ABS, UV-resistant	
Operating temperature	-40 °C to +80 °C	
Humidity	95 % @ 25 °C	
Max. wind speed	216 km/h	

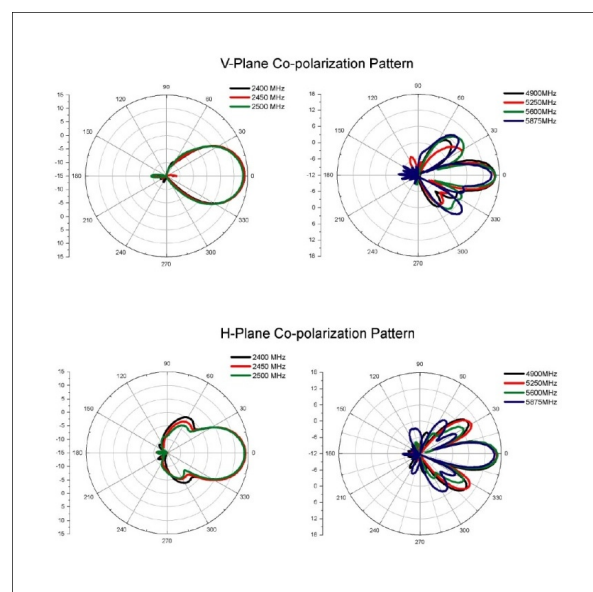
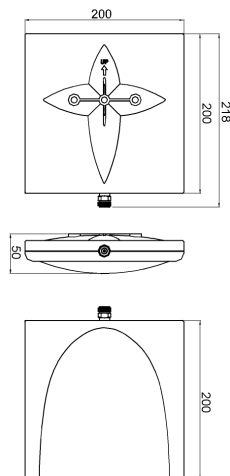

ACC-EMP-N-dual

Order No.: 600499

Description:

This overvoltage protector is used to largely prevent overvoltages from the outside from harming the electronics and the network, e.g. in the case of a thunderstorm. It is designed for up to 6 GHz and can therefore easily be used for systems from 2 GHz to 5 GHz. With its N plug and N jack, it can be placed between the RTNC-N cable and other N cables. The overvoltage protector should be mounted at the transition point to the building and must be sufficiently earthed.

Insertion loss: 0.4 dB at 2.4 GHz, 0.7 dB at 5.5 GHz

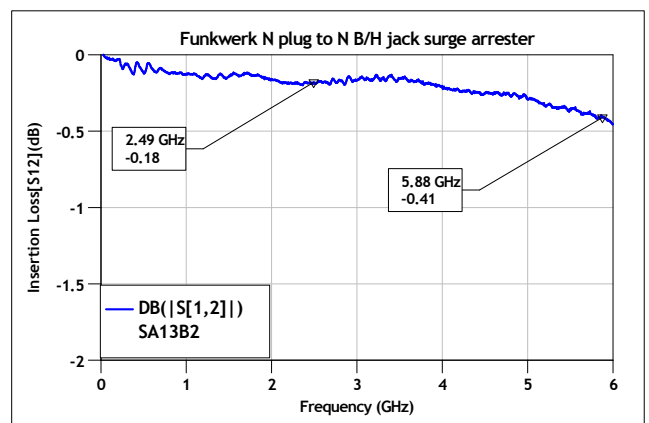
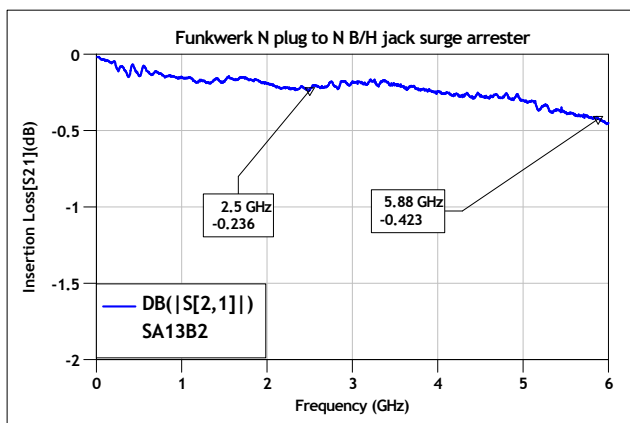
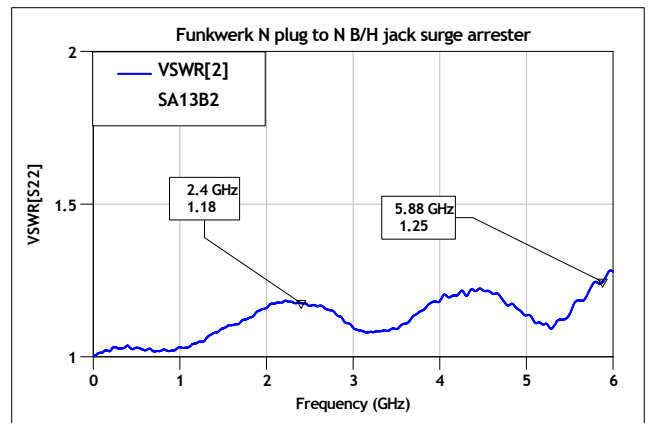
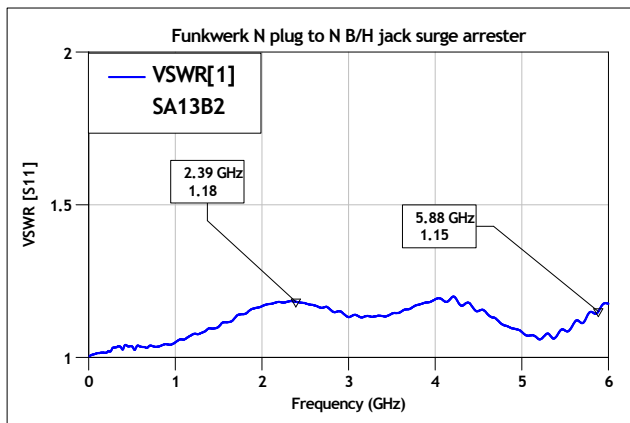
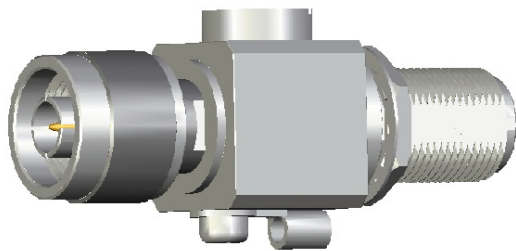

Low-Loss antenna cables

The antenna cables made from Low-Loss ULA/LMR400 coaxial cables and suitable for outdoor installations. The cables meet the demand of the Teldat Access Points and antennas. The connectors are mounted with water protected shrink material.



Order number	Description	Specification	Typical application	Attenuation**	
				2,4 GHz	5 GHz
600507	CAB-RTNC-N-0,5m	RTNC Plug N Plug	W11065n to a ANT-N-20-5G Dual Polarization or as adaptor cable from W1002n/WI-Serie to CAB-N	0,7 dBm	1,2 dBm
5500001541	CAB-RSMA-N-0,5m ***	RSMA Plug N Plug	W2003n-ext to ANT-N-11-5G or adaptor cable to CAB-N	1,5 dBm	2,0 dBm
5500000846	CAB-N-3m	N Plug N Jack	N-N- Extension cable	1,1 dBm	1,6 dBm
5500000847	CAB-N-6m	N Plug N Jack	N-N- Extension cable	1,8 dBm	2,7 dBm
5500000848	CAB-N-9m	N Plug N Jack	N-N- Extension cable	3 dBm	4 dBm
600509*	CAB-N-20m	N Plug N Jack	N-N- Extension cable	6 dBm	10 dBm
600500	CAB-RTNC-1m	RTNC Plug RTNC Jack	W1002n/WI-Serie to ANT-Omni-5-2G-1,2m	0,5 dBm	0,9 dBm
600501	CAB-RTNC-3m	RTNC Plug RTNC Jack	W1002n/WI-Serie to ANT-Omni-5-2G-1,2m	1,0 dBm	1,8 dBm
600502	CAB-RTNC-5m	RTNC Plug RTNC Jack	W1002n/WI-Serie to ANT-Omni-5-2G-1,2m	1,6 dBm	2,6 dBm
600505	CAB-RSMA-RTNC-0,2m	RSMA Plug RTNC Jack	RS-Serie to ANT-Omni-5-2G-1,2m	0,5 dBm	0,9 dBm
600504*	CAB-RSMA-RTNC-3m	RSMA Plug RTNC Jack	RS-Serie to ANT-Omni-5-2G-1,2m	1,6 dBm	2,6 dBm

* While stock last

** Attenuation values are only approximately

*** High flexible ULA198 cable

Teldat GmbH - Suedwestpark 94
 90449 Nuremberg, Germany
 Phone: +49-911 9673 - 0
 Fax: +49-911 688 07 25
 E-mail: info@bintec-elmeg.com - www.bintec-elmeg.com

Antenna Overview
 Subject to technical changes